

TECHNICAL BULLETIN

Document:	TB_T014_024		
Date:	15/02/18		
Subject:	Aggiornamenti 2018	2018 Update	
Reference:	Table	Item	Code
	Multiple	Multiple	Multiple
Accomplishment:	R1_2018		

A major update kit will be released for the T014 chassis following the safety requirements issued by the FIA during 2017.

All the enlisted parts will be MANDATORY to comply the FIA F4 championship technical regulations, the parts classification will be updated accordingly.

A comprehensive kit will be available in Tatuus with the following part number:
1614K18001 2018 Update kit

FRONT ANTI-INTRUSION PANEL

A frontal anti-intrusion panel will be bolted to the front bulkhead in order to improve the frontal strength of the survival cell in the unlikely event of a frontal impact on sharp bodies.

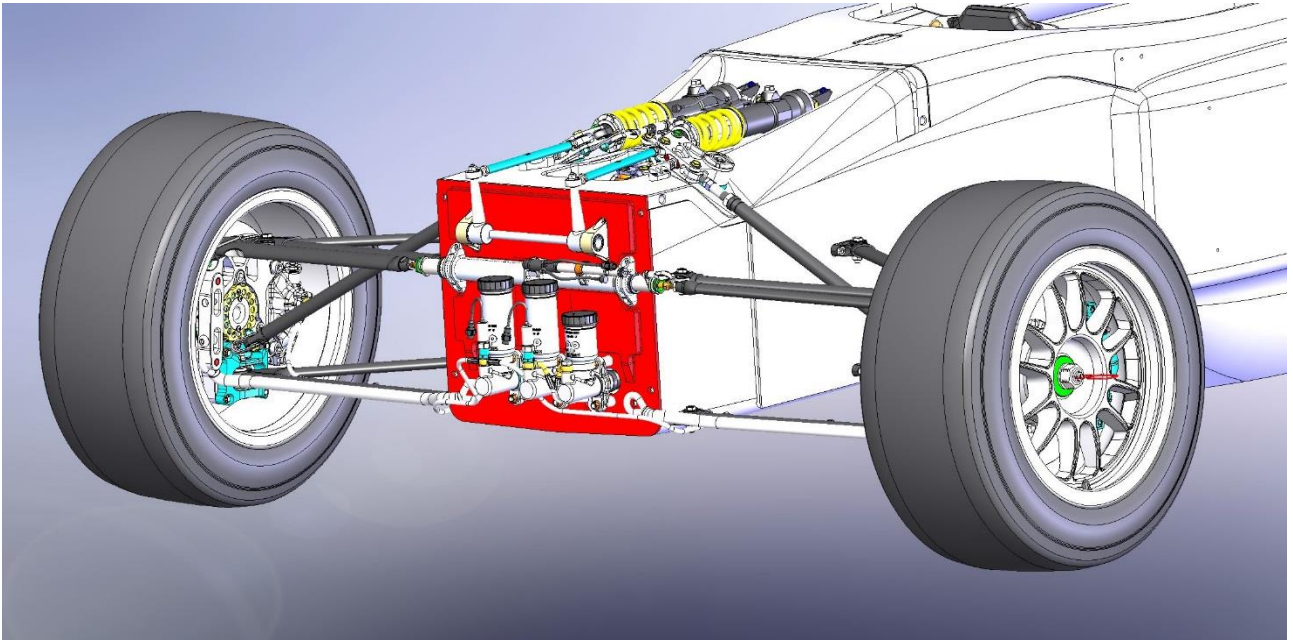

The front nosebox will be installed 5mm forward compared to the 2017 position, the bolts and the front damper cover will be provided in the update kit.

REAR CRASHBOX

A new version of the rear crash structure will be supplied in order to diminish the deceleration threshold during a rear impact.

This new structure will feature a low profiled jacking hook, here below some guidelines in order to help the design of garage tools.

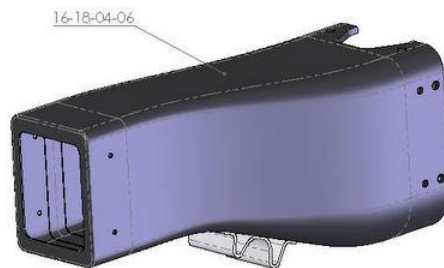
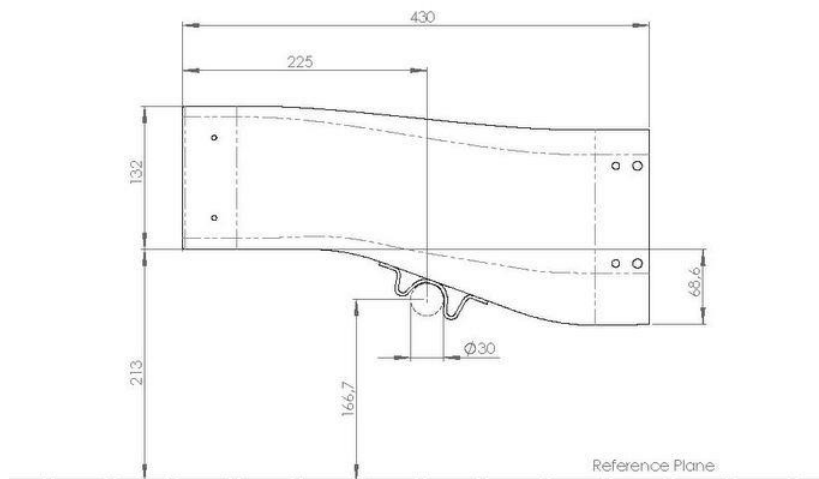

FIA 2018 Spec.
 The peak deceleration over the first 225 mm of deformation does not exceed 27g.
 The maximum deceleration does not exceed 27g for more than a cumulative 15ms.
 Revised jacking points:
 Geometrically NOT the first point of contact between the nose and the RIS;
 Protrude no more than 45mm from surface of RIS.

The rear impact structure will be provided with the relevant bolts and nuts and with a new rain light bracket (rain light to remain the same)